

Fletcher Model LHD General Specifications



Model LHD

Underground horizontal drilling equipment

- Rotational torque up to 3390 N-M
- Chainless drill feed carriage with thrust up to 22.4 kN
- Hollow shaft drill chucks for EW, NQ, BQ rods
- Straight rotary drill systems
- In hole motor drill systems

Features

- Skid mount, dolly tow system, rubber tired or crawler drive undercarriages
- 480 or 575 VAC permissible Electrics
- Load sense hydraulic system

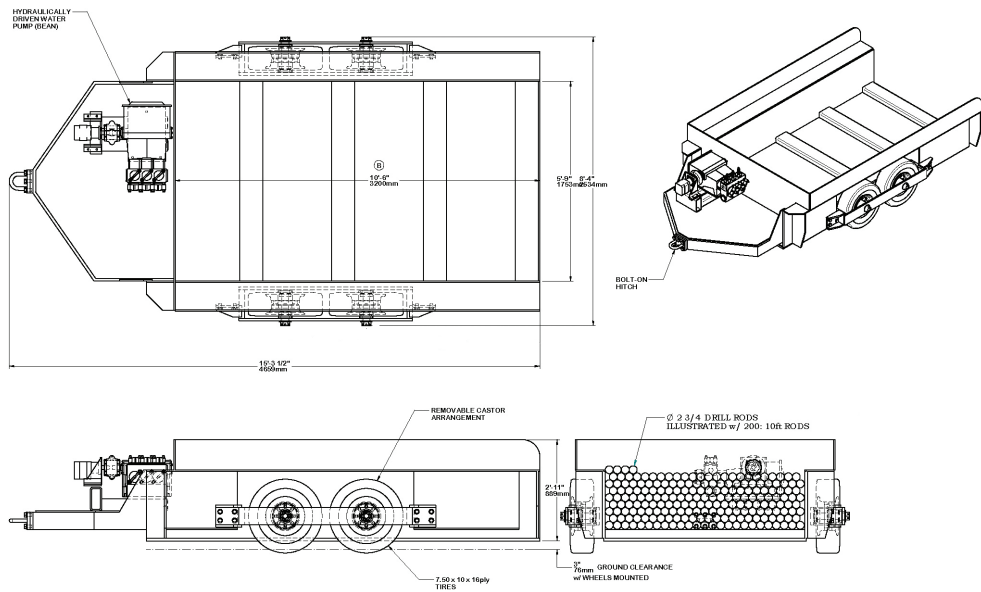
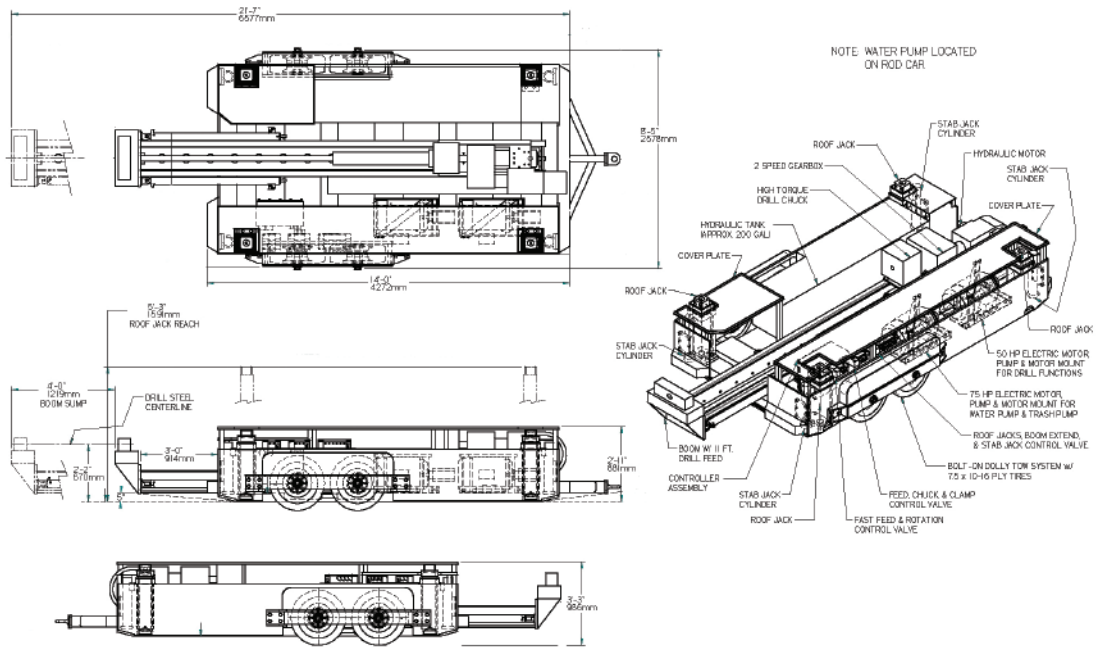

"Fletcher" is a trademark of J.H. Fletcher & Co.

Komatsu Mining Corp. Group
mining.komatsu

Product designs, specifications and/or data in this document are provided for informational purposes only and are not warranties of any kind. Product designs and/or specifications may be changed at any time without notice. The only warranties that apply to sales of products and services are standard written warranties, which will be furnished upon request.

Komatsu, Joy, Montabert, P&H and other trademarks and service marks used herein are the property of Komatsu Ltd., Komatsu Mining Corp., or their respective owners or licensees.

© 2017 Komatsu Mining Corp. All rights reserved.

