

LOG STACKER SPECIFICATIONS



3592
3594

3592 & 3594 Log Stackers

Two & Four Wheel Drive

70,000 lbs. (31,752 kgs) Operating Lift Capacity

24 ft., (7.3152 m) Lift Height (Highest of any comparable machines)

Note: Optional equipment may be shown in photo.

LeTourneau

FORESTRY
PRODUCTS

Built on Experience. Driven by Vision.



POWER ENGINES

DETROIT DIESEL ENGINE

Model	Series 60
Tier 3, D-DEC 5	
Rated Brake HP (SAE) @ 2100 RPM	400 - 475 BHP

CUMMINS DIESEL ENGINE

Model	QSX - 15
Rated Brake HP (SAE) @ 2100 RPM	400 - 475 HP 298 - 354 kw

POWER TRAIN

3592 SL TWO WHEEL DRIVE

4B AC Generator, (400 kw)
 N-11 DC Traction Motors, 200 HP (Front)
 N3-TL Drivers, Ratio 58.39:1 (Front)
 LeTourneau Solid State AC-DC Phase Controls

3594 SL FOUR WHEEL DRIVE

7B AC Generator, (700 kw)
 N-11 DC Traction Motors, 200 HP (Front)
 C-10 DC Traction Motors, 100 HP (Rear)
 N3-TL Drivers, Ratio 58.39:1 (Front)
 N3-TL Drivers, Ratio 58.39:1 (Rear)
 LeTourneau Solid State AC-DC Phase Controls

24 VOLT DC ELECTRIC SYSTEM

Batteries	Two (2) 12 - Volt
Alternator	24 - Volt DC 75 Amp

AC POWER SYSTEM

POWER SYSTEM	AC Motor	HP	KW
Hoist (Two Speed)	# 5 AC	75	56
Tilt	# 3 AC	35	26
Tusk	# 3 AC	35	26
Kicker	# 2 AC	20	15

HYDRAULIC STEERING

Rack and Pinion with Hydraulic Motor		
	<u>US</u>	<u>METRIC</u>
Piston Pump	30 GPM	113.6 LPM



TIRES AND WHEELS

STANDARD

Front	33.25 x 35 - 38 Ply, E - 3
Rear, 3592	29.5 x 25 - 28 Ply, L - 3
Rear, 3594	33.25 x 35 - 38 Ply, E - 3

OPTIONAL

Front	33.25 x 35 - 50 Ply, E - 4
Front	33.25 x 35 - 44 Ply, L - 3 / E - 3
Front (Smooth)	33.25 x 35 - 44 Ply, L - 4
Rear, 3592 (Smooth)	29.5 x 25 - 34 Ply, L - 5
Rear, 3594 (Smooth)	33.25 x 35 - 44 Ply, L - 4
Rear, 3594	33.25 x 35 - 50 Ply, E - 4

BRAKES

Operating Brake	Dynamic Regenerative Electric
Service Brake	Air Caliper / Disc.
Parking	Fail Safe Air Caliper / Disc - STD
Hoist	Fail Safe Air Caliper / Disc - STD

AXLES

Front	Rigid
Rear	Oscillating

SERVICE REFILL CAPACITIES

	<u>US</u>	<u>METRIC</u>
Fuel Tank	268 gallons	1,014 liters
Driver (Front)	7 gallons	26.5 liters
Driver (Rear)	7 gallons	26.5 liters
Hydraulic Steering	25 gallons	94.5 liters

ESTIMATED FUEL USAGE (3592)

	<u>US</u>	<u>METRIC</u>
* Estimated average usage	7 GPH	26.5 LPH,

ESTIMATED FUEL USAGE (3594)

	<u>US</u>	<u>METRIC</u>
* Estimated average usage	8 GPH	30 LPH

* **Lowest fuel usage of any comparable size machines.**
 (Less fuel burned results in better air quality by reducing the amount of carbon dioxide emissions, and resulting in a smaller carbon footprint. Also, less fuel burned results in a longer engine life.)



OPERATING CAPACITIES, WEIGHTS AND DIMENSIONS

	<u>US</u>	<u>METRIC</u>
Operating Capacity	70,000 lbs.	31,751 kgs
Operating Weight (approximate)	135,000 lbs.	61,236 kgs
Lift Height	24' - 0"	7.32 m
Lifting Speed (High Speed)	60 FPM	18.29 m / min
Lowering Speed (High Speed)	75 FPM	24.37 m / min
Forward Tilt at Maximum Height	25°	
Rear Tilt at Maximum Height	12°	
Travel Speed (Standard) (Forward and Reverse Infinity Variable)	0 - 14 MPH	0 - 22.5 KPH
Turning Radius @ 65 degrees		
Outside Rear Tire	26' - 7"	8.10 m
Outside Front Tire	20' - 6"	6.25 m
Tusk Opening (Max to Fork Tip)	14' - 6"	4.42 m
Clearance Under Tusk (Closed)	9' - 6"	2.90 m

STANDARD CONFIGURATION

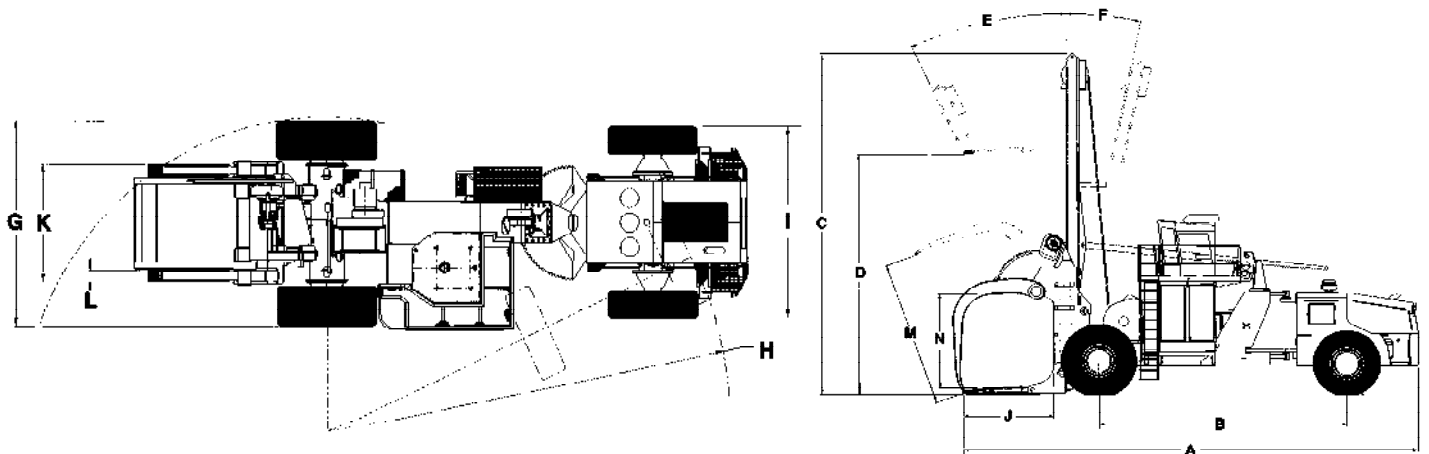

	<u>US</u>	<u>METRIC</u>
(A) Overall Length (Mast Vertical)	43' - 5"	13.25 m
(B) Wheelbase	22' - 0"	6.71 m
(C) Overall Height (Minimum 24' - 0" Lift)	34' - 0"	10.36 m
(D) Lift Height	24' - 0"	7.32 m
(E) Mast Tilt Forward	25°	
(F) Mast Tilt Rear	12°	
(G) Overall Width (Outside Tires) - Front	14' - 7"	4.44 m
(H) Turning Radius	26' - 7"	8.10 m
(I) Overall Width (Outside Tires) - Rear	12' - 2"	3.71 m
(J) Fork Length (Usable)	8' - 9"	2.67 m
(K) Fork Spacing (Outside to Outside)	8' - 4"	2.53 m
(L) Fork Width, Standard	10"	.83 m
(M) Tusk Opening (Maximum to Fork Tip)	14' - 6"	4.42 m
(N) Clearance Under Tusk, Standard (Closed)	9' - 6"	2.90 m
Clearance Under Tusk, Optional Hi-Cube (Closed)	11' - 6"	3.53 m
Minimum Ground Clearance (Mast)	1' - 1"	.33 m



STANDARD EQUIPMENT

OPERATOR'S CAB

Universal Control Center (Joystick Control)
 Standard Control Center (In lieu of Joystick Control)
 Defroster Fans (2)
 Air Horn
 Foot Rest
 Cab Heater (Electric)
 Illuminated Instrument Panels
 Insulated Deluxe Cab
 Radio, AM / FM, CD Player
 Adjustable Air Seat and Suspension / Seat Belt
 Windshield Wipers (Two Speed)
 Air Hose in Cab

GAUGES

Air Cleaner Restriction
 Air Pressure
 Engine Coolant Temperature
 Engine Oil Pressure
 Hour - Meter / Voltmeter (Battery Charge)
 Murphy Engine Gauge
 Hydraulic Tank Level Gauge

INDICATORS AND ALARMS

Amber Indicators:

- Check Engine - Detroit Diesel and Cummins
- Dynamic Braking
- Service Brake

Audible Alarm:

- Blower Motor Failure
- Converter System Failure
- Engine Warning (Low Oil Pressure, Hi-Coolant Temp)
- System Air Pressure (Low)

Red Indicators:

- Blower Motor Failure
- Converter System Failure
- Engine Warning (Low Oil Pressure, Hi-Coolant Temp)
- Low Fuel Warning
- Stop Engine - Detroit Diesel Only

ELECTRICAL

400 KW AC Generator (2 - wheel, Air cooled)
 700 KW AC Generator (4 - wheel, Air cooled)
 AC Work Lights (5 - 500W)
 Armature Converters (Parallel)
 Back Up Alarm
 Back Up Lights
 Contactor (AC), IEC (Tusk, Kicker, Steer, Tilt, Hoist)
 DC Motors, 200 HP-Front / 100 HP-Rear (Air Cooled)
 Diagnostic Test Meter
 Dual Field Converters (4 - wheel)
 Tusk Motor Overload Cutout

LeTourneau Technologies, America, Inc. has made every effort to make these specifications as accurate as possible. However, we reserve the right to make changes and improvements in equipment, materials, and specifications at any time without notice. To insure most current information, please contact your LeTourneau representative.



STANDARD EQUIPMENT (CONTINUED)

ELECTRICAL (CONTINUED)

Two Speed Hoist with Air Disc Brake
 Steering Assist (Electronic)

ENGINE ACCESSORIES

24 Volt Electrical System
 Two - Stage Dry Air Cleaner
 Engine Fuel Filter (Spin - On)
 Engine Oil Filter (Spin - On)
 Fan Clutch

STRUCTURAL

24' - 0" Lift Height Rail
 Powered Tilt Engine Hood
 Service Platform (Cab, Hoist, Tilt and Control Box)
 Tusk (Curved)
 Tilt Rack Grease Gutter

OPTIONAL EQUIPMENT

OPERATOR'S CAB

Red Dot Air Conditioner (Roof Mounted)
 Fire Extinguisher
 Sun Visors (Front and Rear)
 Windshield Wipers (Intermittent)
 Tilt Operator's Console (Standard Control Center)
 Cab Heater (Water)

ELECTRICAL

Additional AC Light (500W)
 Beacon (Amber, Blue, or Red)
 Electrical Outlet, Cab (120VAC)
 Emergency Stop (Two Actuators)
 Heaters (Battery)
 Overload Cutout (Hoist, Kicker)
 Strip Heaters (Cabinet, Axles)
 Turn Signals
 Electric Hoist Brakes

ENGINE ACCESSORIES

Heaters (Oil and Water) 110 VAC or 230 VAC

STRUCTURAL

Positive Arm Kickers
 Service Platform and Ladder (Tusk)
 Tusk (Straight)
 Hi-Cube Carriage Assembly

GENERAL

Ansul 4 Nozzle Fire Suppression System
 Auto Lube System (Frame Only, or Full Machine)

Troutdale, OR
 1-503-669-1276

Lakewood, WA
 1-253-588-1726

Redding, CA
 1-530-365-0175

Coeur d' Alene, ID
 1-208-765-4989

Prince George, BC
 1-250-649-0679

Fax: 1-503-666-6681
 E-mail: letourneautechnologies.com

3592 LOG STACKER



"Environmentally Friendly, No Hydraulic Cylinders to Leak & Pollute the Water"



"Feed the Mill"



3592 with "Optional Hi-Cube Carriage"



"Full Truck Loads"



"High Decking"